

PROPRIETARY NOTICE: This document contains proprietary information of LASER TECHNOLOGY, INC. Neither the document or said proprietary information shall be published, reproduced, copied, disclosed, or used for any purpose other than consideration of this document without the express written permission of a duly authorized representative of said company.

REVISION HISTORY				
REV	ECO/DCR	DESCRIPTION	DATE / DRAWN	APPROVED
01		PRODUCTION RELEASE	05/24/12 W.R.	

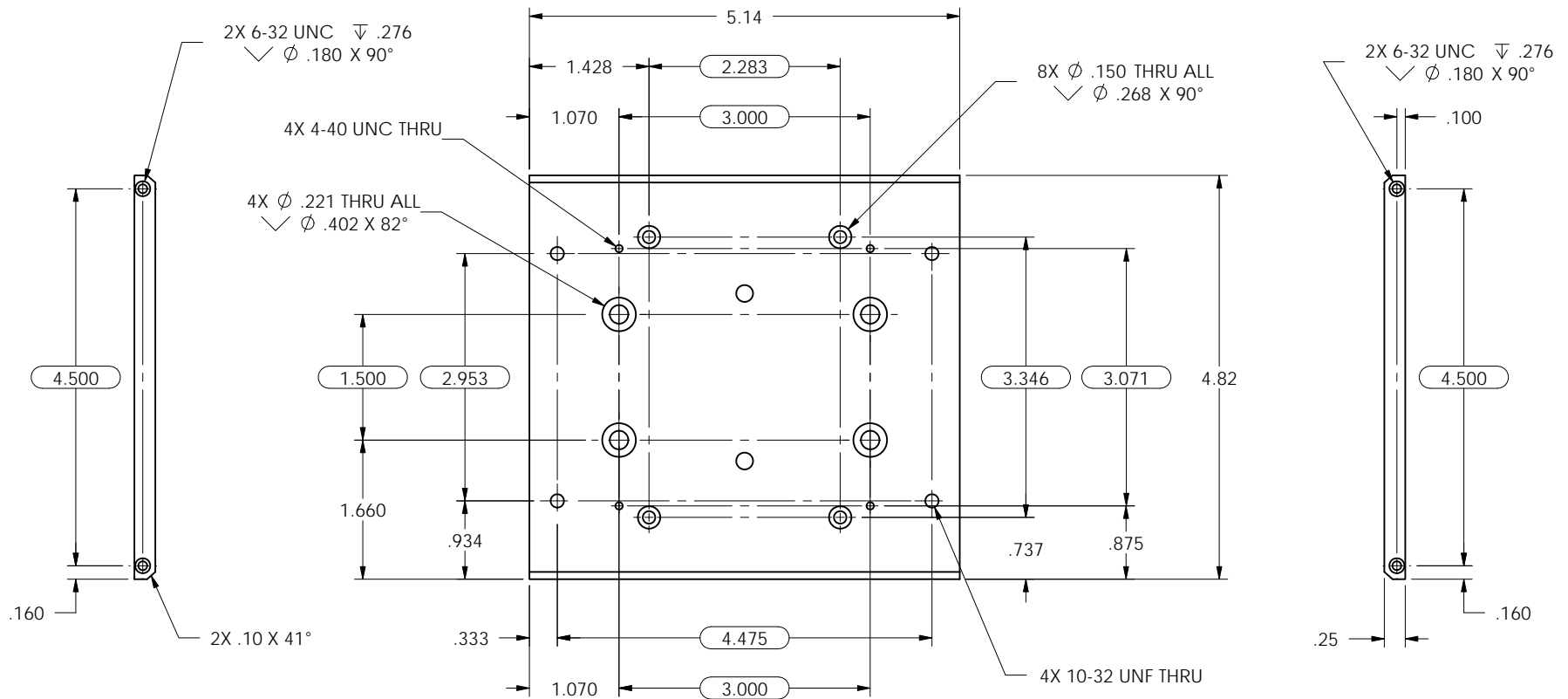

NOTES: UNLESS OTHERWISE SPECIFIED.

INDICATES INSPECTION DIMENSION

- SEE SHEET 2 FOR ADDITIONAL DIMENSIONS.
- FINISH: POWDER COAT BEIGE FINE TEXTURE SEMI-GLOSS, MASK THREADS CARDINAL INDUSTRIAL FINISHES #T241-BG137 OR EQUIVALENT

APPLICABLE SPECIFICATIONS	UNLESS OTHERWISE SPECIFIED DIMENSIONS ARE IN INCHES TOLERANCES: X \pm .1 ANGLES: \pm 1/2° DECIMALS: .XX \pm .01 FINISH: 125 \sphericalangle .XXX \pm .005 .XXXX \pm .0010	APPROVALS		7070 South Tucson Way Centennial Colorado 80112
		SIGNATURE W. REIT	DATE 07/12/10	
MATERIAL ALUMINUM ALLOY 6061-T6	PROTECTIVE/DECORATIVE FINISH SEE NOTES	APPROVED BY XXX	APEX FILE NAME XXX	SIZE FILE NAME A 1154817_01
		SCALE 1/1	DRAWING NOT TO SCALE	PART/DRAWING NO. 1154817
				REV 01
				SHEET 1 OF 2

PART/DRAWING NO.
1154817
SHEET
1 OF 2
REV
01

PROPRIETARY NOTICE: This document contains proprietary information of LASER TECHNOLOGY, INC. Neither the document or said proprietary information shall be published, reproduced, copied, disclosed, or used for any purpose other than consideration of this document without the express written permission of a duly authorized representative of said company.

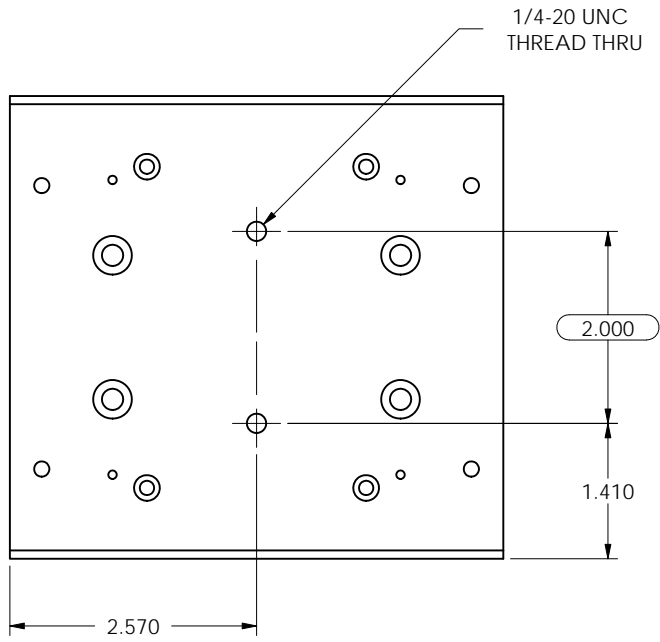
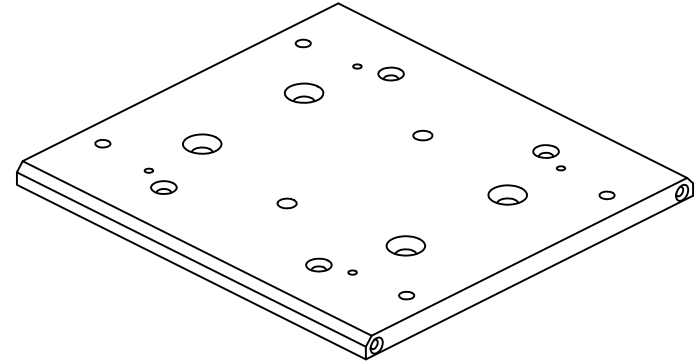

NOTES: UNLESS OTHERWISE SPECIFIED.
 INDICATES INSPECTION DIMENSION

APPLICABLE SPECIFICATIONS	UNLESS OTHERWISE SPECIFIED DIMENSIONS ARE IN INCHES TOLERANCES: X ± .1 ANGLES: ± 1/2° DECIMALS: .XX ± .01 FINISH: 125 ✓ .XXX ± .005 .XXXX ± .0010	APPROVALS		 7070 South Tucson Way Centennial Colorado 80112	
		SIGNATURE W. REIT	DATE 07/12/10		TITLE INDUSTRIAL MOUNT PLATE, MOUNTING
MATERIAL ALUMINUM ALLOY 6061-T6	APPROVED BY	SIZE A	FILE NAME 1154817_01	PART/DRAWING NO. 1154817	REV 01
PROTECTIVE/DECORATIVE FINISH SEE SHEET 1	APEX FILE NAME XXX	SCALE 1/1	DRAWING NOT TO SCALE		SHEET 2 OF 2

PART/DRAWING NO.
1154817
SHEET
2 OF 2
REV
01